



## STREET SCENE EQUIPMENT, INC.

365 McCormick Avenue

Costa Mesa, Ca. 92626

Phone (714) 426-0590 Fax (714) 426-0591

950-60511  
2002 - 2006  
DODGE RAM  
STD CAB & QUAD CAB  
STREET HITCH

### INSTALLATION INSTRUCTIONS

**VERY IMPORTANT !** Read and understand all directions and check the following parts list before starting installation. Hardware Furnished for all application. Not all hardware will be used.

PARTS LIST			
1	Street Hitch	2	***** 9/16" Lock Washers # 01013
2	1/2"-13 X 1 1/2" Hex Bolts # 11107	2	***** 9/16" Flat Washers # 70916
6	1/2" Lock Washers # 10124	2	***** M14-35 Bolts # 01012
6	1/2" Nuts # 11110	2	1/2" Washers ( Thick ) # 10111
2	1/4" Thick Blocks # 10107 Square on side	6 FT	Fish Wire # 10106
2	1/4" Thick Blocks # 10108 Square In Center	4	1/2"-13 X 1 3/4" Carriage Bolts # 11109
1	Instruction Sheets	1	Hitch Label # 60011

\*\*\*\*\* **NOTE: USED ON 2002 MODELS AND 2003 MODELS BUILT BEFORE 11/01/02**

TOOL LIST	
1/2" Socket, 22MM Socket, Ratchet, Extension, Torque Wrench, Pliers, Drill Motor, 1/2" Drill Bit	

### # NOTE: SPARE TIRE CAN BE RETAINED ON MOST VEHICLES

1. Remove bumper and round bumper support crossmember. Remove spare tire.
2. Remove all hardware from bag and identify.
3. Review drawings one thru four to acquaint yourself with installing procedure.
4. Refer to figure 1 and note the mounting holes in hitch. Vehicles built before 11/01/02 will use mounting holes A,B, and D. Vehicles built after 11/02/02 will use mounting holes A, C, and D.
5. On all models slide or push the 1/4" square blocks into the frame over the large round holes in frame. Refer to figure 1 & 2.
6. Cut the 6 FT. fish wire into two 3 foot pieces. Wrap the fish wire around the threads of carriage bolt. Fishwire bolts thru slots in frame ( See figure 3 ) and into square blocks pushed into frame. See figure 4.
7. On trucks built after 11/02/02 do the same on the rear most hole in frame. See figures 2 & 3.
8. With the aid of another person carefully raise the SSE hitch to the carriage bolts in frame. Be careful not to push the carriage bolts into the frame. ( "Tip" leave 6" to 12 " of the fish wire on bolts and guide through hole in hitch ).
9. On trucks built before 11/02/02 you will find a threaded nut in the frame alligning with the slot in hitch " B ". Use the black M14-35 bolts, lock washers and flat washers and secure the hitch. Position hitch squarely with frame.
10. On all models use the hitch as a template and drill a 1/2" hole through frame in the rearmost hole in hitch " D ". Insert a 1/2"-13 X 1 1/2" bolt with thick washer in frame and through hole in hitch and secure with a 1/2" inch nut and lock washer. This third bolt is necessary for proper weight capacity. Tighten all bolts to 75 FT LBS.

11. Set the roll pan to bed. Tape into position. From the back side mark around receiver hole. Remove roll pan and carefully cut a rectangular hole in roll pan to expose the receiver hole. It is advised to cut the hole about 3 inches longer on each side so that the ball mount pin can be easily installed without having to crawl under truck.
12. Install roll pan to vehicle. Follow installation instructions included with roll pan. **NOTE:** Receiver mount will protrude past the license bucket on some vehicles.
13. Install part number 950-61100 flip-up license kit. This will move the license plate about 3/4" back from bucket in roll pan. Always mount flip kit so that license will flip up.

**FIGURE 1**

## INSTALLATION INSTRUCTIONS

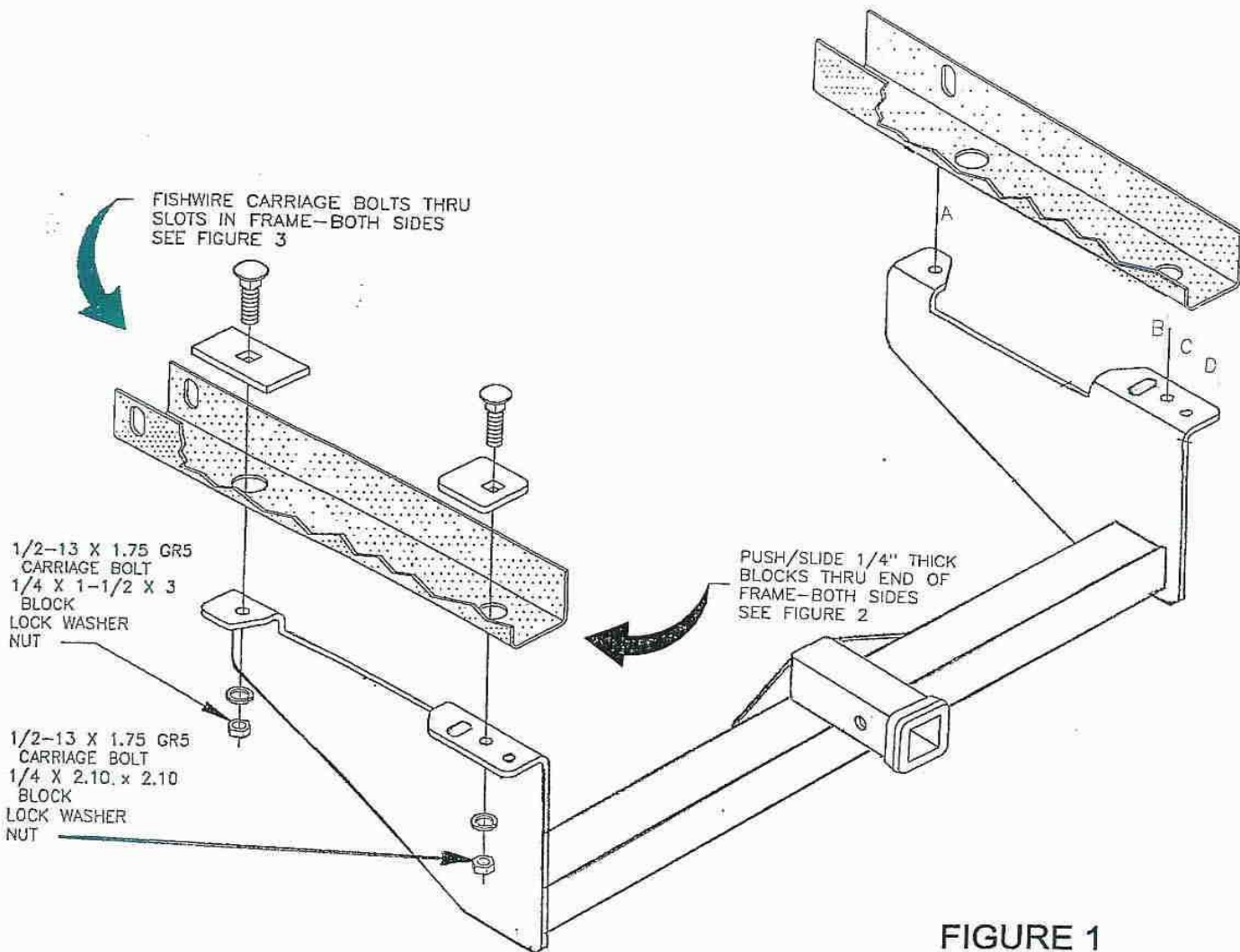

# INSTALLATION INSTRUCTIONS

VEHICLE

HITCH NO.

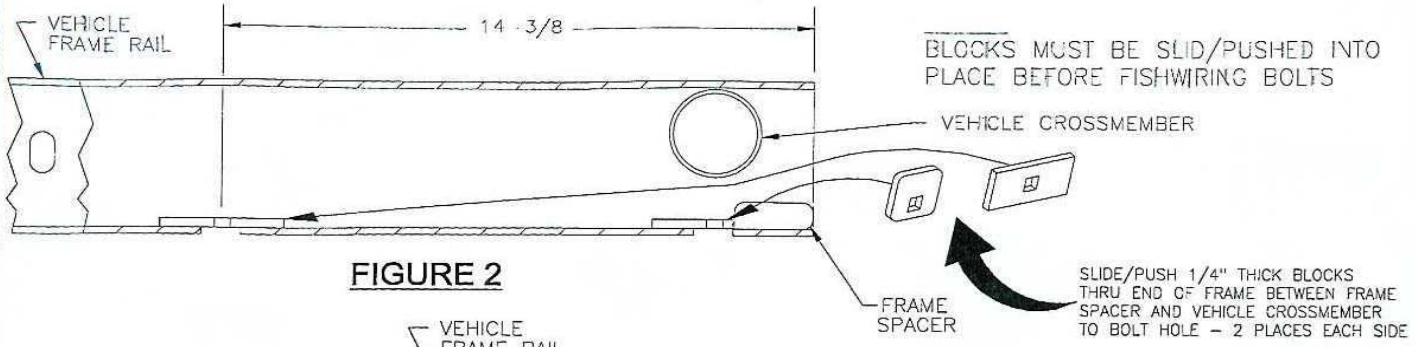

FIGURE 2

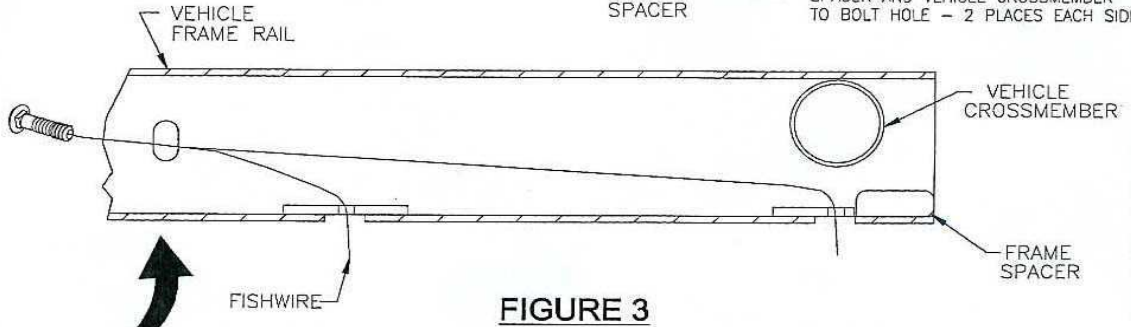

FIGURE 3

FISHWIRE CARRIAGE BOLTS THRU SLOTS IN FRAME TO BOLT HOLES 2 PLACES EACH SIDE

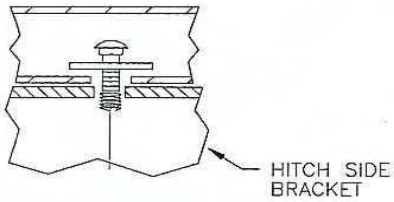

FIGURE 4